

SNA/SDLC Link/iX

Technical Data

**For HP 3000 Series 900
Computer Systems
Product Number
30291 A**

SNA/SDLC Link/iX provides the network connection for SNA services running on an HP 3000 Series 900, such as SNA IMF/iX, SNA NRJE/iX, LU 6.2 API/iX, and SNA DHCF/iX. System Network Architecture (SNA) is IBM's comprehensive specification for distributed data processing networks. SNA/SDLC Link/iX emulates the functions of SNA's Transmission Control, Path

Control, and Data Link Control layers on an HP 3000.

SNA/SDLC Link supports the simultaneous operation of two or more SNA services. SNA/SDLC Link allows the HP 3000 to appear as a Node Type 2.0 or Node Type 2.1 device when connected to an IBM mainframe or a Node Type 2.1 device when connected to an IBM AS/400. SNA/SDLC

Link can support several logical unit types that include LU 1, LU 2, LU 3, and LU 6.2, depending upon the SNA service running. SNA/SDLC Link also provides link level alerts to IBM's network management product, NetView.

Features

- The SNA/SDLC Link emulates the functions of the lower three SNA layers and can support several SNA services running on the same HP 3000.
- SNA/SDLC Link consists of software, a hardware interface card, and a cable.
- Delayed alert reporting of link errors to NetView console.
- Operators on the HP node can send operator generated alerts to the NetView console.
- The hardware interface card in SNA/SDLC Link reduces CPU overhead.
- User applications run concurrently with SNA data communications.

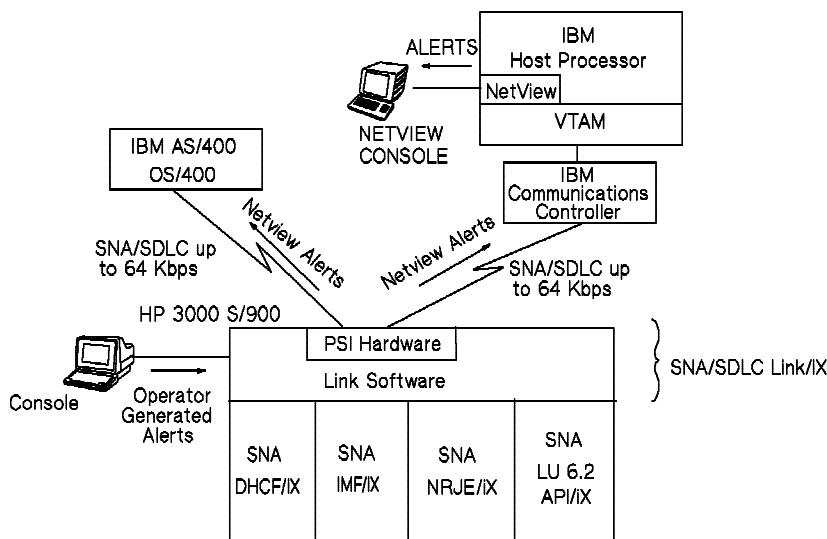

- Each SNA/SDLC Link connects to a separate data communications line, either dial-up or leased.
- Multiple SNA/SDLC Links allow concurrent connection to multiple hosts, or multiple lines to a single host.
- A maximum data communications line speed of 64 Kbps is supported.
- Node management provides a friendly interface for configuration, event tracing, and logging.
- Supports EIA RS-366 and CCITT V.25 Auto Call.

Functional Description

SNA/SDLC Link provides the connection to an IBM System/370-compatible mainframe in an SNA network, through an IBM 37xx communications controller or to an IBM AS/400 in an SNA network. SNA/SDLC Link allows the HP 3000 to emulate the functions of the Transmission Control, Path Control, and Data Link Control SNA layers.

Each SNA/SDLC Link connects to a single switched or nonswitched data communications line. The HP 3000 supports multiple SNA/SDLC Links for connection to multiple IBM mainframes and/or IBM AS/400s, or multiple data communications lines to a single mainframe or AS/400. The maximum line speed supported is 64 Kbps for SNA/SDLC Link/iX.

The Node Management interface provides the Network Manager with an easy-to-use tool for configuration, event logging, and event tracing. SNA/SDLC Link provides support for IBM's NetView product. This enables the HP 3000 Series 900 to act as an Entry Point in IBM's NetView environment. If an HP node's link goes down, SNA/SDLC Link will send a delayed link-level alert to the NetView console when the link comes back up. This feature also allows an operator on the HP node to send operator generated alerts to the NetView console.

Functional Specifications

SNA/SDLC Link provides the connection between an HP 3000 and an IBM System/370 or compatible host processor in an SNA network or between an HP 3000 and an IBM AS/400 in an SNA network. It manages the SNA/SDLC protocol for a switched or nonswitched data communications line, through synchronous modems.

SNA/SDLC Link/iX supports synchronous modem speeds up to 64Kbps as described below. SNA/SDLC Link requires synchronous modems that support the following handshake signals: DTR, DSR, RTS, CTS, CD, RI. Modems must also provide transmit and receive clocks for the SDLC interface and ensure ground isolation between the communication systems. Some

examples of modems that are supported for SNA/SDLC Link are:

HP 37230A

AT&T 201C
 AT&T 208 BR
 AT&T 209A
 AT&T 500B
 AT&T 2024A
 AT&T 2048A
 AT&T 2096A
 AT&T 2248A
 AT&T 2556 DSU
 AT&T 2596 DSU
 CODEX 2640
 CODEX 2660
 CODEX 2680
 CODEX 2260

GTE LENKURT 56K

DYNATECH LDM 22

Link Contents

SNA/SDLC Link consists of protocol handling software, an interface card, and a modem cable.

The Interface Card

The interface card for SNA/SDLC Link/iX is the Programmable Serial Interface (PSI) card. The PSI has a 68000 family microprocessor.

The Central Bus PSI is designed with LSI circuitry, and the Precision Bus PSI is designed with LSI and VLSI circuitry, both supporting the HP 3000 Series 900 architecture. Reference the individual HP 3000 processor data sheets for specific

information regarding the appropriate PSI card.

PSI/Features

- Data communications protocol handling
- Character handling and buffer storage capability
- Built-in diagnostics and self-test
- Online diagnostics run under MPE iX
- Collects data volume and error statistics
- Modem interface up to 64 Kbps
- Compatible with HP and common Telco/PTT modems in full- and half-duplex modes
- SDLC protocol compatible
- EIA RS-232-C and CCITT V.24 and V.35 interfacing standards
- Auto Call capability, compatible with EIA RS-366 and CCITT V.25 standards

The Direct Memory Access (DMA) controller on the PSI provides channels that link data buffers in onboard RAM with the HP 3000 interface and data communications devices. DMA moves data between external devices and onboard RAM concurrent with microprocessor operation. This ability to transfer data concurrently with instruction execution enables the interface card to achieve high throughput rates. Also contributing to the high throughput rate is the interface card's ability to transfer the last correctly received block of data to the HP 3000 CPU as it is also processing and buffering the next block of data coming from the communication channel.

Frees the HP 3000 for Other Tasks

Since the interface card microprocessor performs all of the communication data link protocol management, the HP 3000 is relieved of the task. Specifically, serialization, SDLC protocol management, frame/block management, and data buffering are all performed by the interface card. The interface card frees the HP 3000 to perform other tasks, making it a more efficient resource.

Note: The HP 3000 CPU must still process message formats and higher level procedures.

Additional flexibility is achieved with auto call capability. By connecting an interface card to a modem and auto call unit and adding a phone number to the link configuration file, a remote connection in a dial-up environment can occur anytime without the intervention of an operator.

High Data Integrity

When the SNA/SDLC Link is initialized, the interface card performs a hardware self-test. This ensures the hardware is functional and will perform the job properly. When data is transmitted, parity checking is enabled. If data is transmitted incorrectly, retransmission occurs.

Product Requirements

If connecting to an IBM mainframe

- SNA/SDLC Link/iX requires an IBM System/370 or compatible mainframe (Model 370, 30xx, or 43xx) with an IBM 37xx or compatible communications controller. The following software must be running on the host and communications controller:
 - MVS/SP, MVS/XA, MVS/ESA, VSE, or VM
 - ACF/VTAM
 - ACF/NCP

If connecting to an IBM AS/400

- SNA/SDLC Link/iX requires an IBM AS/400 running OS/400 Version 1.2 or later operating system.

HP will support certain versions, releases, modifications, and PTF levels of the above software. Your HP Sales Representative or System Engineer can determine whether SNA/SDLC Link can be supported with your particular configuration. The Network Implementation Support Plan (NISPP) will help the customer engineer determine support requirements in advance for the particular network.

- A terminal supported by V/3000 (in addition to the system console) is required for the HP 3000 Node Management software.

- A switched or nonswitched data communications line is required between the SNA/SDLC Link and the host communications controller.
- An external clock signal must be provided for operation at 64 Kbps.

SNA/SDLC Link/iX Product Requirements

- An HP 3000 Series 900 computer system
- MPE XL Release 2.2 or MPE iX Release 4.0 or later operating system. For AS/400 connectivity, MPE iX Release 4.0 or later is required.

Installation and Configuration Policy

The customer is responsible for loading the SNA/SDLC Link/iX software onto the system.

Hewlett-Packard will install the PSI card and perform minimum configuration of SNA/SDLC Link/iX in order to verify minimum product functionality. This activity is included in the product purchase price.

Customer Responsibility

Prior to having HP personnel onsite to install the PSI card and perform minimum configuration of SNA/SDLC Link/iX, the customer is responsible for the following:

- Providing HP with the information necessary to complete the Network Implementation and Support Plan (NISP) including:

- System configurations
- Logical network map identifying relevant traffic flow
- Physical network map identifying relevant network hardware components.
- Installing a switched or nonswitched line between the HP 3000 system and the communications controller on the host system – with a matched pair of synchronous modems that are certified for use with HP 3000 systems at each end of the line.
- Conducting the appropriate tests to ensure that the line and modems are functioning properly.
- Verifying that the necessary host mainframe software is installed and configured to support SNA/SDLC Link/iX. The customer should contact their HP Sales Representative for typical host parameter values or consult the “HP SNA Products: ACF/NCP and ACF/VTAM Guide” (5958-8543) for details.
- Updating the HP 3000 system to the proper release level and installing the SNA/SDLC Link/iX software using AUTOINST. Refer to the HP 3000 MPE iX Update Manual (36123-90001).
- Verifying that all of the necessary software modules have been successfully installed by AUTOINST and are at the correct version levels using the NMMAINT.PUB.SYS utility.
- Performing full system backups as necessary and ensuring that the HP 3000 system and personnel with HP 3000 system management knowledge are

available when HP is onsite to complete the PSI card installation and perform minimum configuration of SNA/SDLC Link/iX.

The customer is also responsible for completing the configuration in order to fully integrate SNA/SDLC Link/iX into the existing customer network after HP has completed the minimum configuration of SNA/SDLC Link/iX.

HP Responsibility

Following the installation of SNA/SDLC Link/iX, HP is responsible for the following:

- Installing and verifying the PSI card for SNA/SDLC Link/iX.
- Connecting the SNA/SDLC Link/iX hardware to the customer’s communication line (only if available at installation time).
- Confirming that all of the necessary software modules have been installed and are at the correct version level.
- Configuring the SNA/SDLC Link/iX product to a minimum configuration (1 PU and 1 LU) in order to verify software and hardware functionality.
- Verifying the SNA/SDLC Link/iX configuration by issuing the SNACONTROL START command and ensuring that the PU to SSCP session becomes active.

These steps complete HP’s portion of the installation and minimum configuration of SNA/SDLC Link/iX.

Additional Implementation Assistance

For implementation needs that go beyond installation, the customer can either provide self-support, or can purchase additional services from HP. These services include Network Startup and HP ConsultLine. In addition, the customer can also purchase service from HP on a time-and-materials basis.

Network Startup includes implementation scheduling and coordination assistance, network configuration and verification testing, and network documentation.

System Environment

SNA/SDLC Link/iX is available on the HP 3000 Series 900 with MPE XL Release 2.2 or MPE iX Release 4.0 or later (MPE iX Release 4.0 or later for IBM AS/400 connectivity).

Note: SNA/SDLC Link does not support user access to its intrinsics. See your local HP office for information about an HP special product for this purpose.

Ordering Information

30291A SNA/SDLC Link/iX requires service contract for hardware.

Select **one** PSI option AND **one** cable option AND **one** User License option. The User License Option must align with the MPE iX License. Upgrade credits may be used where applicable.

PSI Options:

- 001** Central Bus PSI (for HP 3000 CIO systems)
- 002** Precision Bus PSI (for HP 3000 NIO systems)
- 090** No PSI (software only)

Cable Options:

- 010** RS-232 connection
- 020** V.35 connection
- 025** RS-232 auto-dial connection
- 099** No cable (software only)

User License Options:

- OAF** 20-user license
- UCY** 40-user license
- UA9** 64-user license
- UBD** 100-user license
- UCN** 160-user license
- UAT** Unlimited user license

Upgrade Credit Options:

- UD8** Credit for 20-user license
- UCZ** Credit for 40-user license
- UB9** Credit for 64-user license
- UD9** Credit for 100-user license
- UDV** Credit for 160-user license

- UBP** Credit for Unlimited user license
- OCD** Credit for Processor Option 310
- OGJ** Credit for Processor Option 315
- OCE** Credit for Processor Option 320
- OCF** Credit for Processor Option 330
- OGL** Credit for Processor Option 335
- OGM** Credit for Processor Option 340
- UEK** Credit for Processor Option 350

In order to receive the upgrade credit, customers must select the upgrade credit option that pertains to their current processor/user license option in addition to the new user license option on the same order.

Support Products

HP offers a spectrum of support service products to help plan, implement, operate, and manage your multivendor network throughout the network lifecycle.

For more information, contact your HP Sales Representative, or refer to the HP data sheets for specific support services.

Documentation

For SNA/SDLC Link/iX:

30291-61000 SNA Link/iX Node Manager's Guide